

STOP VALVE (GLOBE VALVE)

- PLASTIC BODY WITH HIGH RESISTANCE TO CORROSION, CHEMICALS AND WEAR.
- COMPACT SIZE AND AFFORDABLE TYPE
- ALSO AVAILABLE FOR FLOW CONTROL OR NEEDLE VALVE (SPECIAL ORDER)

BASIC SPECIFICATIONS

VALVE TYPE ————— STOP VALVE (GLOBE VALVE)
 SIZE ————— 15 mm—100 mm (1/2 inch—4 inch)
 BODY MATERIAL ————— **U-PVC** **PP**
 SEAL MATERIAL / PACKING — **EPDM** **PTFE** etc.
 CONNECTION / FLANGED — JIS5K, JIS10K, DIN, ANSI
 SOCKET — JIS, DIN, ANSI
 THREADED— Rc, Rp, NPT
HIGH PURITY SERIES — **LUBRICANT FREE**

	FLUID TEMPERATURE	MAXIMUM WORKING PRESSURE (NORMAL TEMPERATURE) MPa(kgf/cm ²)	CONNECTION METHOD		
			FLANGED	SOCKET	THREADED
U-PVC	0°C ~ 50°C	1.0 {10.2}	○	○	○
PP	-20°C ~ 80°C	0.75 {7.7}	○	—	○

NOTES The maximum working pressure is the value including the water hammer pressure. Be careful that the maximum working pressure is not exceeded during use.
 * Concerning the allowable pressure for each temperature and material, see the technical documents at the end of this catalog.



PARTS LIST **MANUAL**

PRODUCT MODEL CODE LIST	ACTUATION	TYPE	OPERATING SYSTEM	BODY MATERIAL	SEAL MATERIAL	CONNECTION	STANDARD	SIZE	HIGH PURITY SERIES
MANUAL	V	ST	MH	*	*	*	*	***	1
	⋮	⋮	⋮	⋮	⋮	⋮	⋮	⋮	⋮
	V MANUAL VALVE	ST STOP VALVE (GLOBE VALVE)	MH ROUND HANDLE	U U-PVC P PP	E EPDM V FKM T PTFE	S SOCKET N THREADED F FLANGED	J JIS 1 JIS10K 5 JIS5K	015 15mm ? 100 100mm	1 LUBRICANT FREE

STOP VALVE (GLOBE VALVE)

TYPE—VSTMH

CONNECTION / FLANGED—JIS, DIN, ANSI

FLANGED

15 mm — 32 mm
(1½ inch — 1¼ inch)

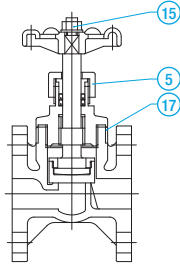

40 mm — 50 mm
(1½ inch — 2 inch)

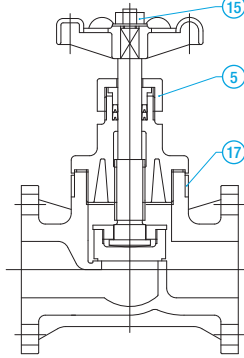

65 mm — 100 mm (2½ inch — 4 inch)

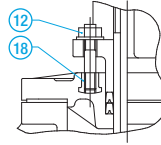
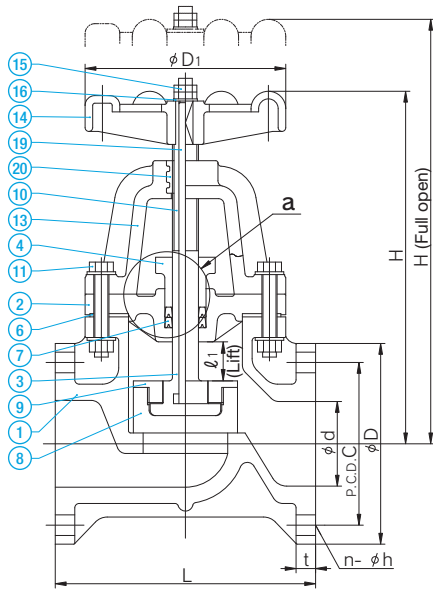

DETAILS OF SECTION "a"

PART NO. / NAME	QTY	MATERIAL
① BODY	1	U-PVC, PP
② BONNET	1	U-PVC, PP
③ STEM (1)	1	U-PVC, PP
④ PACKING GLAND	1	U-PVC, PP
⑤ GLAND NUT(2)	1	U-PVC
⑥ PACKING (3)	1	EPDM, PTFE, etc.
⑦ GLAND PACKING	1 SET	PDM, PTFE, etc.
⑧ DISC	1	PP
⑨ STEM HOLDER	1	PP
⑩ STEM WITH TRAPEZOIDAL SCREW	1	C3604Used for 65 to 100 mm.
⑪ HEX BOLT/NUT	8	SUS304Used for 65 to 100 mm.
⑫ STUD BOLT/NUT	2	SUS304Used for 65 to 100 mm.
⑬ STEM SUPPORT	1	PPUsed for 65 to 100 mm.
⑭ HANDLE WHEEL	1	PP
⑮ NUT (A)	1	U-PVCUsed for 15 to 50 mm.
	2	SUS304Used for 65 to 100 mm.
⑯ WASHER	1	U-PVCUsed for 15 to 50 mm.
	1	SUS304Used for 65 to 100 mm.
⑰ REINFORCEMENT RING	1	SUS304Used for 15 to 50 mm for body material of PP.
⑱ STUD NUT	2	C3604Used for 65 to 100 mm.
⑲ EMBEDDED STEM FITTING	1	SS400Used for 65 to 100 mm.
⑳ EMBEDDED SUPPORT FITTING	1	BC6Used for 65 to 100 mm.

NOTES (1) For 65 to 100 mm, PP only.
(2) Used for 15 to 50 mm.
(3) PTFE+EPDM when the packing is made of PTFE.

■ JIS, DIN (Unit: mm)

								JIS5K				JIS10K				DIN PN10			
mm	d	D ₁	ℓ ₁	H	H (FULL OPEN)	L	t	D	C	n	h	D	C	n	h	D	C	n	h
15	18	66	8	124	132	85	12	80	60	4	12	95	70	4	15	95	65	4	14
20	24	66	8	132	140	95	14	85	65	4	12	100	75	4	15	105	75	4	14
25	28	91	11	150	161	110	14	95	75	4	12	125	90	4	19	115	85	4	14
32	37	91	13	154	167	135	16	115	90	4	15	135	100	4	19	140	100	4	18
40	41	135	17	210	230	190	16	120	95	4	15	140	105	4	19	150	110	4	18
50	52	135	22	228	252	200	16	130	105	4	15	155	120	4	19	165	125	4	18
65	67	185	35	310	345	220	18	155	130	4	15	175	140	4	19	185	145	4	18
80	78	185	35	324	359	240	18	180	145	4	19	185	150	8	19	200	160	8	18
100	100	185	40	379	419	290	18	200	165	8	19	210	175	8	19	220	180	8	18

■ ANSI (Unit: inch)

											ANSI CLASS150			
inch	mm	d	D ₁	ℓ ₁	H	H (full open)	L	t	D	C	n	h		
1/2	15	0.71	2.60	0.31	4.88	5.20	3.35	0.47	3.50	2.38	4	0.62		
3/4	20	0.94	2.60	0.31	5.20	5.51	3.74	0.55	3.88	2.75	4	0.62		
1	25	1.10	3.58	0.43	5.91	6.34	4.33	0.55	4.25	3.12	4	0.62		
1 1/4	32	1.46	3.58	0.51	6.06	6.57	5.31	0.63	4.62	3.50	4	0.62		
1 1/2	40	1.61	5.31	0.67	8.27	9.06	7.48	0.63	5.00	3.88	4	0.62		
2	50	2.05	5.31	0.87	8.98	9.92	7.87	0.63	6.00	4.75	4	0.75		
2 1/2	65	2.64	7.28	1.38	12.20	13.58	8.66	0.71	7.00	5.50	4	0.75		
3	80	3.07	7.28	1.38	12.76	14.13	9.45	0.71	7.50	6.00	4	0.75		
4	100	3.94	7.28	1.57	14.92	16.50	11.42	0.71	9.00	7.50	8	0.75		

MANUAL

THREADED

SOCKET

STOP VALVE (GLOBE VALVE)

TYPE—VSTMH

CONNECTION / SOCKET—JIS, DIN, ANSI THREADED—Rc, Rp, NPT

THREADED 15 mm – 32 mm
(1½ inch – 1¼ inch)

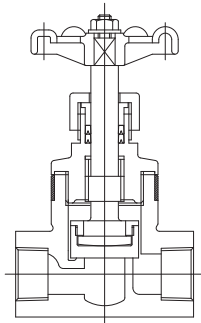

40 mm – 50 mm
(1½ inch – 2 inch)

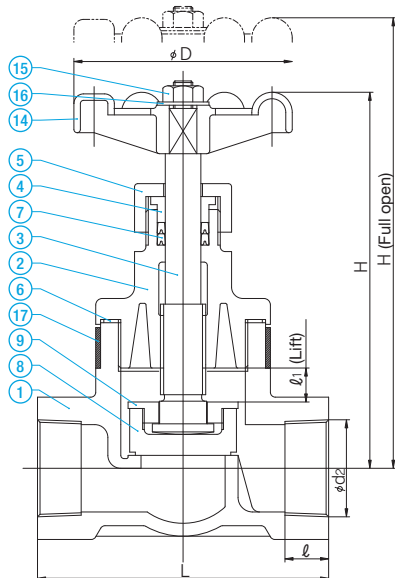

SOCKET 15 mm – 25 mm
(½ inch – 1 inch)

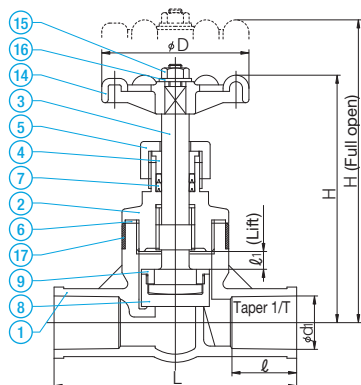

PART NO. / NAME	QTY	MATERIAL
① BODY	1	U-PVC, PP
② BONNET	1	U-PVC, PP
③ STEM	1	U-PVC, PP
④ PACKING GLAND	1	U-PVC, PP
⑤ UNION NUT	1	U-PVC
⑥ PACKING	1	EPDM, PTFE, etc.
⑦ GLAND PACKING ⁽¹⁾	1 SET	EPDM, PTFE, etc.
⑧ DISC	1	PP
⑨ STEM HOLDER	1	PP
⑭ HANDLE WHEEL	1	PP
⑮ NUT (A)	1	U-PVC
⑯ WASHER	1	U-PVC
⑰ REINFORCEMENT RING	1	SUS304... Used when the body material is PP.

NOTES (1) PTFE+EPDM when the gland packing is made of PTFE.

■ JIS, DIN (Unit: mm)

mm	D	ℓ ₁	H	H (FULL OPEN)	JIS						DIN				
					SOCKET				THREADED		SOCKET				
					U-PVC				d ₂	ℓ	L	U-PVC			
d ₁	ℓ	1/T	L	d ₂	ℓ	L	d ₁	ℓ	1/T	L					
15	66	8	124	132	22.40	30	1/34	110	Rc 1/2	15	85	20	16	6	82
20	66	8	132	140	26.45	35	1/34	130	Rc 3/4	18	95	25	19	8	98
25	91	11	150	161	32.55	40	1/34	150	Rc 1	20	110	32	22	11	114
32	91	13	154	167	-	-	-	-	Rc 1 1/4	25	135	-	-	-	-
40	135	17	218	235	-	-	-	-	Rc 1 1/2	25	140	-	-	-	-
50	135	22	237	259	-	-	-	-	Rc 2	27	180	-	-	-	-

■ ANSI (Unit: inch)

inch	mm	D	ℓ ₁	H	H (FULL OPEN)	ANSI						
						SOCKET			THREADED			
						d ₂	d ₁	ℓ	L	d ₂	ℓ	L
1/2	15	2.60	0.31	4.88	5.20	0.848	0.59	1.18	4.33	1/2-14NPT	0.59	3.35
3/4	20	2.60	0.31	5.20	5.51	1.058	0.71	1.38	5.12	3/4-14NPT	0.71	3.74
1	25	3.58	0.43	5.91	6.34	1.325	0.98	1.58	5.91	1-11 1/2NPT	0.79	4.33
1 1/4	32	3.58	0.51	6.06	6.57	-	-	-	-	1 1/4-11 1/2NPT	0.98	5.32
1 1/2	40	5.31	0.67	8.58	9.25	-	-	-	-	1 1/2-11 1/2NPT	0.98	5.51
2	50	5.31	0.87	9.33	10.20	-	-	-	-	2-11 1/2NPT	1.06	7.09

CONSTANT FLOW VALVE

- USE OF THE POWER OF THE FLUID ELIMINATES THE USE OF ANY POWER SOURCE, RESULTING IN POWER SAVING.
- HIGH ACCURACY (WITHIN +/-6% OF FULL SCALE) AND LARGE RANGEABILITY (RATIO OF MAX. AND MIN. FLOW SETTING VALUES)
- THE SET FLOW CAN BE CHANGED BY HANDLE OPERATION. CAN ALSO BE USED AS AN INHIBITOR VALVE (COMPLETE CLOSURE).
- EQUIPPED WITH OPENING DEGREE INDICATOR THAT ALLOWS FOR CHECKING OF SET FLOW RATE (m3/hr).
- THE WETTED PART USES CORROSION-RESISTANT AND LIGHTWEIGHT PLASTIC AND ELASTOMER.
- USES SPRING (SUS304) FULLY COATED WITH FLUORORESIN HAVING ADEQUATE DURABILITY AND CHEMICAL RESISTANCE.

BASIC SPECIFICATIONS

VALVE TYPE ————— CONSTANT FLOW VALVE

SIZE ————— 15 mm, 20 mm, 25 mm, 50 mm, 80 mm, 100 mm
(1/2 inch, 3/4 inch, 1 inch, 2 inch, 3 inch, 4 inch)

BODY MATERIAL ————— U-PVC

SEAL MATERIAL ————— EPDM etc.

CONNECTION / FLANGED — JIS5K, JIS10K, DIN, ANSI

HIGH PURITY SERIES — LUBRICANT FREE

	FLUID TEMPERATURE	MAXIMUM WORKING PRESSURE (NORMAL TEMPERATURE) MPa(kgf/cm ²)	
		15mm—80mm	100mm
U-PVC	0°C ~ 50°C	1.0 {10.2}	0.5 {5.1}

NOTES The maximum working pressure is the value including the water hammer pressure. Be careful that the maximum working pressure is not exceeded during use.
* Concerning the allowable pressure for each temperature and material, see the technical documents at the end of this catalog.

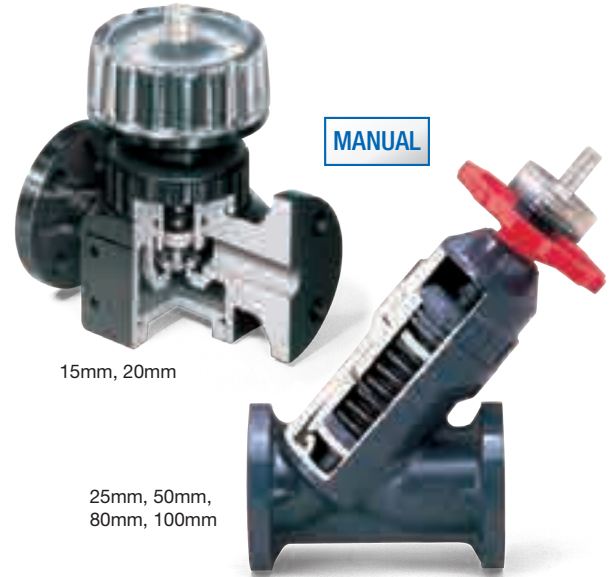

PARTS LIST MANUAL

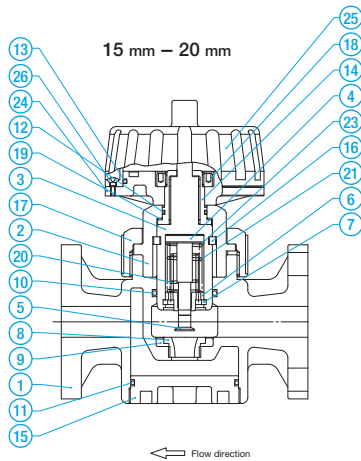

25 mm - 100 mm

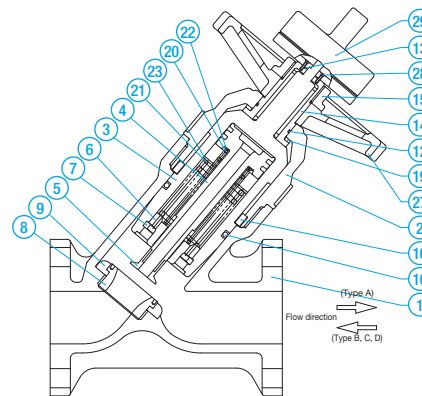

PART NO. / NAME	QTY	MATERIAL	PART NO. / NAME	QTY	MATERIAL
1 BODY	1	U-PVC	12 O-RING (C)	1	EPDM
2 BONNET	1	U-PVC	13 O-RING (D)	1	EPDM
3 CYLINDER	1	U-PVC	14 SLEEVE	1	C3604
4 PISTON	1	U-PVC	15 CAP	1	U-PVC
5 PLUG	1	U-PVC	16 KEY	2	PP (15 - 20mm) U-PVC (25 - 100mm)
6 SPRING SEAT	1	U-PVC	17 THRUST RING	1	PP
7 STOP RING	1	PVDF	18 SPRING (A)	1	SUS304*
8 ORIFICE	1	U-PVC	19 SPRING (B)	1	SUS304*
9 SEAT	1	EPDM, etc.	20 WASHER (B)	1	U-PVC
10 O-RING (A)	1 (15 - 20 mm) 2 (25 - 100 mm)	EPDM, etc. (1)			

Used for 15 - 20 mm only.

PART NO. / NAME	QTY	MATERIAL
11 O-RING (B)	1	EPDM, etc.
17 UNION NUT	1	U-PVC
18 NUT	1	ABS
24 HANDLE BASE	1	ABS
25 HANDLE COVER	1	PC
26 CROSS RECESSED RAISED COUNTERSUNK HEAD SCREW	4	SUS304

Used for 25 - 100 mm only.

PART NO. / NAME	QTY	MATERIAL
22 WASHER (A)	1	U-PVC
27 HANDLE	1	PP
28 FASTENING SCREW	4	C3604
29 OPENING DEGREE INDICATOR	1 SET	ABS, etc.

NOTE (1) For FKM, complete closure is not available.

* SUS304 is coated with fluororesin.

PRODUCT MODEL CODE LIST
[MANUAL](#)

ACTUATION	TYPE	OPERATING SYSTEM	BODY MATERIAL	SEAL MATERIAL	CONNECTION	STANDARD	SIZE	HIGH PURITY SERIES
V	CF	*T	U	E	F	*	***	1
V MANUAL VALVE	CF CONSTANT FLOW	AT TYPE A BT TYPE B CT TYPE C DT TYPE D	U U-PVC	E EPDM V FKM	F FLANGED	1 JIS 10K 5 JIS 5K	015 15mm 100 100mm	1 LUBRICANT FREE

MANUAL

CONSTANT FLOW VALVE

TYPE—VCF
 CONNECTION / FLANGED—JIS, DIN, ANSI

15 mm – 20 mm

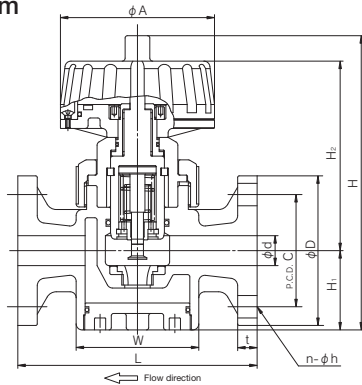

25 mm – 100 mm

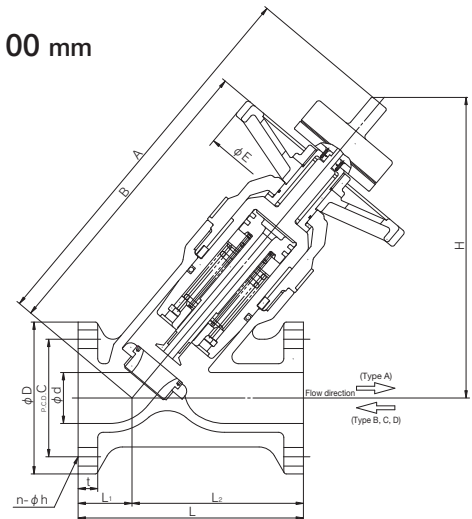

■ JIS, DIN (Unit: mm)

mm	d	W	A	H ₁	H ₂	H	L	t	JIS								DIN			
									JIS 5K				JIS 10K				DIN PN10			
									D	C	n	h	D	C	n	h	D	C	n	h
15	16	82×82	103	51	129	197	160	12	80	60	4	12	95	70	4	15	95	65	4	14
20	20	82×82	103	53	127	197	160	13	85	65	4	12	100	75	4	15	100	75	4	14

■ JIS, DIN (Unit: mm)

mm	d	L ₁	L ₂	A	B	H	E	L	t	JIS								DIN			
										JIS 5K				JIS 10K				DIN PN10			
										D	C	n	h	D	C	n	h	D	C	n	h
25	25	40	120	272	201	218	150	160	14	95	75	4	12	125	90	4	19	115	85	4	14
50	52	55	175	390	309	307	210	230	20	130	105	4	15	155	120	4	19	165	125	4	18
80	78	70	210	484	387	377	210	280	22	180	145	4	19	185	150	8	19	200	160	8	18
100	100	85	325	623	483	446	250	410	22	200	165	8	19	210	175	8	19	220	180	8	18

■ ANSI (Unit: inch)

inch	mm	d	W	A	H ₁	H ₂	H	L	t	ANSI							
										ANSI CLASS150							
										D	C	n	h	D	C	n	h
1/2	15	0.63	3.23×3.23	4.06	2.01	5.08	7.76	6.30	0.47	3.50	2.38	4	0.63	3.86	2.76	4	0.63
3/4	20	0.79	3.23×3.24	4.06	2.09	5.00	7.76	6.30	0.51	3.86	2.76	4	0.63				

■ ANSI (Unit: inch)

inch	mm	d	L ₁	L ₂	A	B	H	E	L	t	ANSI							
											ANSI CLASS150							
											D	C	n	h	D	C	n	h
1	25	0.98	1.57	4.72	10.71	7.91	8.58	5.91	6.30	0.55	4.25	3.13	4	0.63	5.98	4.74	4	0.75
2	50	2.05	2.17	6.89	15.35	12.17	12.09	8.27	9.06	0.79	7.25	6.00	8	0.75	8.66	7.50	8	0.75
3	80	3.07	2.76	8.27	19.06	15.24	14.84	8.27	11.02	0.87								
4	100	3.94	3.35	12.80	24.53	19.02	17.56	9.84	16.14	0.87								

NEEDLE VALVE

- OUR ORIGINAL SPECIAL SHAPE PLUG ALLOWS FOR HIGHLY ACCURATE FLOW CONTROL.
- SHUTOFF VALVE AND RUBBER SEAT ALLOW FOR COMPLETE SEALING.
- INDEPENDENT FROM SHUTOFF VALVE, IT MAINTAINS HIGH-ACCURACY CONTROL FUNCTION FOR A LONG PERIOD.
- INSPECTION AND CLEANING OF INSIDE OF THE VALVE CAN BE PERFORMED WITHOUT DISMOUNTING IT FROM THE PIPE, BY REMOVING THE CAP (15 mm, 20 mm).
- INTEGRALLY MOLDED BODY THAT IS LIGHTWEIGHT, ROBUST AND COMPACT.

BASIC SPECIFICATIONS

VALVE TYPE ————— **NEEDLE VALVE**
SIZE ————— **15 mm—25 mm (1/2 inch—1 inch)**
BODY MATERIAL ————— **U-PVC**
SEAL MATERIAL ————— **EPDM etc.**
CONNECTION / FLANGED — **JIS5K, JIS10K, DIN, ANSI**
HIGH PURITY SERIES ————— **LUBRICANT FREE**

	FLUID TEMPERATURE	MAXIMUM WORKING PRESSURE (NORMAL TEMPERATURE) MPa(kgf/cm ²)
U-PVC	0°C ~ 50°C	1.0 {10.2}

NOTES The maximum working pressure is the value including the water hammer pressure. Be careful that the maximum working pressure is not exceeded during use.
 * Concerning the allowable pressure for each temperature and material, see "Asahi AV Piping Material Technical Document". * For FKM 25 mm, complete sealing is not available.

MANUAL



Flow characteristics

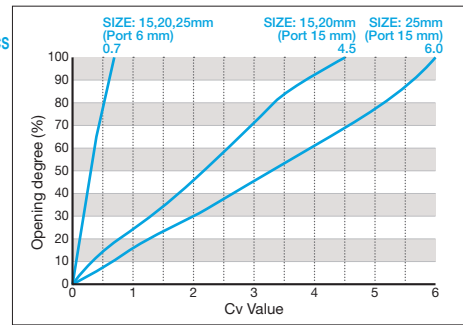

SIZE	PORT SIZE (mm)	
15mm, 20mm	6	15
25mm	6	15

PARTS LIST MANUAL

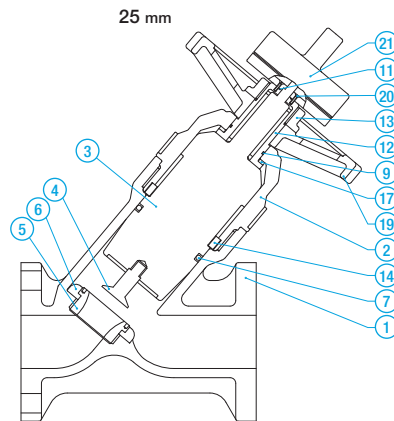
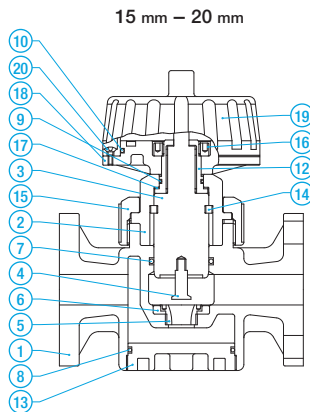

PART NO. / NAME	QTY	MATERIAL	PART NO. / NAME	QTY	MATERIAL
① BODY	1	U-PVC	⑬ CAP	1	U-PVC
② BONNET	1	U-PVC	⑭ KEY	2	PP(15-20mm) U-PVC(25mm)
③ CYLINDER	1	U-PVC	⑰ THRUST RING	1	PP
④ PLUG	1	U-PVC	⑱ HANDLE	1	PC(15-20mm) PP(25mm)
⑤ ORIFICE	1	U-PVC	⑳ MACHINE SCREW	4	SUS304(15-20mm) C3604(25mm)
⑥ SEAT	1	EPDM, etc.			
⑦ O-RING (A)	1	EPDM, etc. (1)			
⑨ O-RING (C)	1	EPDM			
⑫ SLEEVE	1	C3604			

Used for 15 - 20 mm only.

PART NO. / NAME	QTY	MATERIAL
⑧ O-RING (B)	1	EPDM, etc.
⑩ O-RING (D)	1	EPDM
⑮ UNION NUT	1	U-PVC
⑯ NUT	1	ABS
⑱ HANDLE BASE	1	U-PVC

Used for 25 mm only.

PART NO. / NAME	QTY	MATERIAL
⑪ O-RING (E)	1	EPDM
⑳ OPENING DEGREE INDICATOR	1 SET	U-PVC, etc.

NOTES (1) For FKM, complete closure is not available.

PRODUCT MODEL
CODE LIST
MANUAL

ACTUATION	TYPE	OPERATING SYSTEM	BODY MATERIAL	SEAL MATERIAL	CONNECTION	STANDARD	SIZE	HIGH PURITY SERIES
V	ND	MH	U	E	F	*	***	1
⋮	⋮	⋮	⋮	⋮	⋮	⋮	⋮	⋮
V MANUAL VALVE	ND NEEDLE	MH ROUND HANDLE	U U-PVC	E EPDM V FKM	F FLANGED	1 JIS 10K 5 JIS 5K	015 15mm 025 25mm	1 LUBRICANT FREE

MANUAL

NEEDLE VALVE

TYPE—VNDMH
CONNECTION / FLANGED—JIS, DIN, ANSI

15 mm – 20 mm

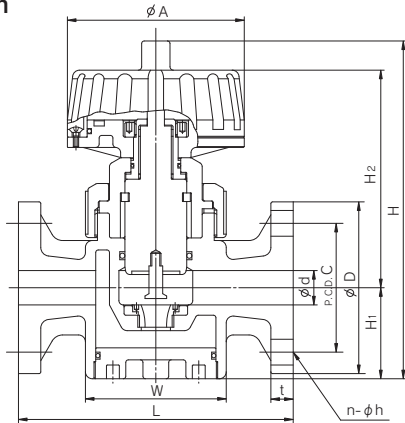

25 mm

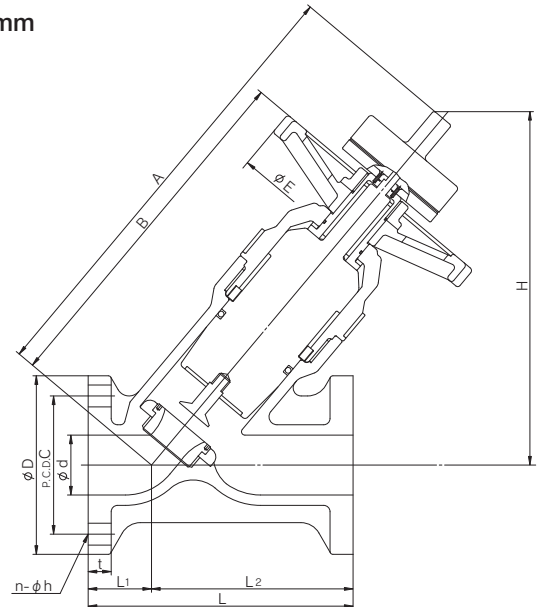

■ JIS, DIN (Unit: mm)

mm	D ₁	W	A	H ₁	H ₂	H ₃	L	t	JIS				DIN			
									JIS 10K				DIN PN10			
									D	C	n	h	D	C	n	h
15	16	82×82	103	51	129	197	160	12	95	70	4	15	95	65	4	14
20	20	82×82	103	53	127	197	160	13	100	75	4	15	105	75	4	14

■ JIS, DIN (Unit: mm)

mm	d	L ₁	L ₂	A	B	H	E	L	t	JIS				DIN			
										JIS 10K				DIN PN10			
										D	C	n	h	D	C	n	h
25	25	40	120	272	201	218	150	160	14	125	90	4	19	115	85	4	14

■ ANSI (Unit: inch)

inch	mm	D ₁	W	A	H ₁	H ₂	H ₃	L	t	ANSI			
										ANSI CLASS150			
										D	C	n	h
1/2	15	0.63	3.23×3.23	4.06	2.01	5.08	7.76	6.30	0.47	3.50	2.38	4	0.63
3/4	20	0.79	3.23×3.23	4.06	2.09	5.00	7.76	6.30	0.51	3.86	2.76	4	0.63

■ ANSI (Unit: inch)

inch	mm	d	L ₁	L ₂	A	B	H	E	L	t	ANSI			
											ANSI CLASS150			
											D	C	n	h
1	25	0.98	1.57	4.72	10.71	7.91	8.58	5.91	6.30	0.55	4.25	3.13	4	0.63

SELF CONTROL VALVE PRESSURE REDUCING TYPE

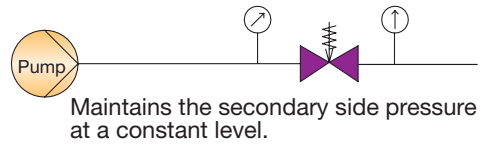

Even when the primary side pressure fluctuates, the valve maintains secondary side pressure constant.

It works using the fluid pressure only, without using any auxiliary power.

Against the fluid power pressing up the piston, the valve uses the force of compression spring to press down the piston so as to keep balance.

For appropriate flow range, see P.237.

BASIC SPECIFICATIONS

- VALVE TYPE — SELF CONTROL VALVE PRESSURE REDUCING TYPE
- SIZE — 15 mm—50 mm (1/2 inch—2 inch)
- BODY MATERIAL — **U-PVC**
- SEAL MATERIAL — **EPDM** etc.
- CONNECTION / FLANGED — JIS, DIN, ANSI
- SOCKET — JIS, DIN, ANSI
- THREADED — Rc, Rp, NPT
- WORKING TEMPERATURE RANGE — 0-50°C
- MAX.ALLOWABLE WORKING PRESSURE — 1.0MPa
- ALLOWABLE PRESSURE RANGE — 0.05-0.9MPa
- HIGH PURITY SERIES — WETTED PARTS LUBRICANT FREE

MANUAL



PRODUCT MODEL CODE LIST

MANUAL

ACTUATION	TYPE	OPERATING SYSTEM	BODY MATERIAL	SEAL MATERIAL	CONNECTION	STANDARD	SIZE	HIGH PURITY SERIES
V	PR	2T	U	*	*	*	***	2
V	PR	2T	U	E EPDM V FKM Z FKM (PTFE coating)	S SOCKET N THREADED F FLANGED	J JIS 1 JIS10K D DIN A ANSI	015 15mm 050 50mm	2 WETTED PARTS LUBRICANT FREE

TYPE What should be filled in the "xxx" section?

NOTES (1) The 15-40 mm (piston) type and 50 mm (diaphragm) type have different internal structure. Be careful when selecting the type of seal material.
(2) For 50 mm, select either E: EPDM or Z: FKM (PTFE coating). (For 15-40 mm, select E: EPDM or V: FKM.)

MANUAL

SELF CONTROL VALVE PRESSURE REDUCING TYPE

CONNECTION / FLANGED, SOCKET — JIS, DIN, ANSI THREADED — Rc, Rp, NPT

50 mm V82 INSIDE STRUCTURE DIAGRAM

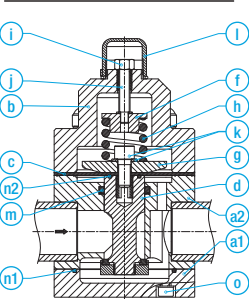

15 mm - 40 mm V182 INSIDE STRUCTURE DIAGRAM

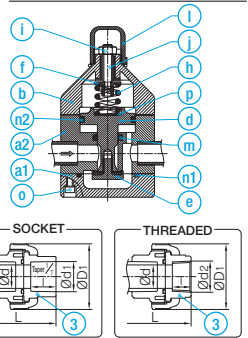

FLANGED

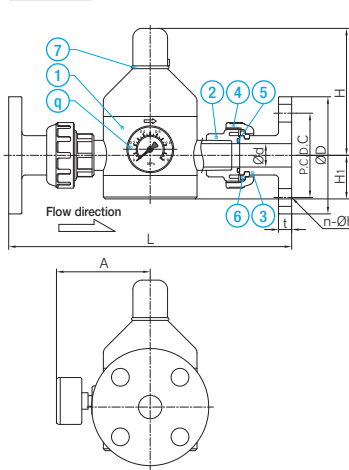

PART NO. / NAME	QTY	MATERIAL	MEMO
a1 BODY (LOWER)	1	U-PVC	
a2 BODY (UPPER)	1	U-PVC	
b HOUSING	1	U-PVC	
c DIAPHRAGM	1	EPDM	Used for V82.
d PISTON	1	U-PVC	
e PISTON BASE	1	U-PVC	Used for V182.
f SPRING PLATE	1	Aluminum	
g COMPRESSOR	1	U-PVC	Used for V82.
h COMPRESSION SPRING	1	Spring steel	
i LOCK NUT	1	Polyamide	
j ADJUSTING SCREW	1		
k BOLT, WASHER	1		Used for V82.
l CAP	1	Polystyrene	
m RING SEAL	1	EPDM	
n1 O-RING (A)	1	EPDM	
n2 O-RING (B)	1	EPDM	
o BOLT, NUT, WASHER	4		
p SPRING SUPPORT PLATE	1		Used for V182.
q PRESSURE GAUGE	1	ABS, etc.	
2 PJ-BODY	2	U-PVC	SELF CONTROL VALVE DEDICATED FOR TRUE UNION
3 END CONNECTOR	2	U-PVC	
4 UNION NUT	2	U-PVC	
5 O-RING (C)	2	EPDM	
6 STOP RING	2	PVDF	Used for flanged type.
7 O-RING (D)	1	EPDM	

JIS, DIN (Unit: mm)

mm	JIS															DIN													
	FLANGED					SOCKET					THREADED					FLANGED DIN PN10/PN16			SOCKET			THREADED							
d	D1	H	H1	A	D	C	n	h	L	t	d1	ℓ	1/T	L	d2	ℓ	L	D	C	n	h	L	t	d1	ℓ	L	d2	ℓ	L
15	15	48	103	30	90	95	70	4	15	221	12	22.11	20 1/34	186	Rc 1/2	15	180	95	65	4	14	208	12	20	16	180	Rp1/2	15	180
20	20	60	137	46	100	100	75	4	15	292	14	26.13	24 1/34	248	Rc 3/4	17	240	105	75	4	14	270	14	25	19	239	Rp3/4	17	240
25	25	70	137	46	100	125	90	4	19	302	14	32.16	27 1/34	260	Rc 1	20	246	115	85	4	14	275	14	32	22	246	Rp1	20	246
32	31	82	178	55	115	135	100	4	19	346	16	38.19	30 1/34	318	Rc 1 1/4	22	306	140	100	4	18	338	16	40	26	306	Rp1 1/4	22	306
40	40	100	178	55	115	140	105	4	19	379	16	48.21	37 1/37	356	Rc 1 1/2	25	330	150	110	4	18	367	16	50	31	331	Rp1 1/2	25	330
50	51	106	213	75	125	155	120	4	19	395	16	60.25	42 1/37	380	Rc 2	28	358	165	125	4	18	395	16	63	38	388.2	Rp2	28	358

ANSI (Unit: inch)

inch	ANSI																										
	FLANGED ANSI CLASS 150					SOCKET					THREADED																
mm	d	D1	H	H1	A	D	C	n	h	L	t	d1	d1'	ℓ	L	d2	ℓ	L	d2	ℓ	L	d2	ℓ	L	d2	ℓ	L
1/2	15	0.59	1.89	4.06	1.18	3.54	3.50	2.38	4	0.62	8.70	0.47	0.848	0.836	0.875	7.52	1/2 -14NPT	0.59	7.09								
3/4	20	0.79	2.36	5.39	1.81	3.94	3.88	2.75	4	0.62	11.50	0.55	1.058	1.046	1.000	9.80	3/4 -14NPT	0.67	9.45								
1	25	0.98	2.76	5.39	1.81	3.94	4.25	3.12	4	0.62	11.89	0.55	1.325	1.310	1.125	10.24	1 -11 1/2NPT	0.79	9.69								
1 1/4	32	1.22	3.23	7.01	2.17	4.53	4.62	3.5	4	0.62	13.62	0.63	1.670	1.655	1.250	12.60	1 1/4 -11 1/2NPT	0.87	12.05								
1 1/2	40	1.57	3.94	7.01	2.17	4.53	5.00	3.88	4	0.62	14.92	0.63	1.912	1.894	1.375	13.82	1 1/2 -11 1/2NPT	0.98	12.99								
2	50	2.01	4.17	8.39	2.95	4.92	6.00	4.75	4	0.75	15.55	0.63	2.387	2.369	1.500	14.57	2 -11 1/2NPT	1.10	14.09								

SELF CONTROL VALVE PRESSURE RELIEF TYPE

This valve is used for piping lines and equipment where excessive pressure needs to be prevented. The T-shaped pipe structure allows the fluid to flow in 3 directions. In addition to the intake and discharge ports located sideways in a straight line (horizontal direction), there is also a discharge port on the lateral side (vertical direction). If the pressure in the horizontal direction exceeds the set pressure, the valve will open so that the fluid is discharged from the vertically located discharge port. The pressure dispersion and closure operation allow the valve to maintain the horizontal pressure constant and reduce the peak pressure. For appropriate flow range, see P.237.

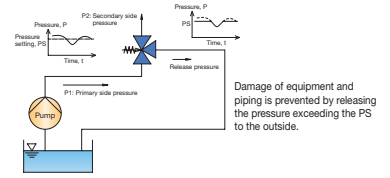

BASIC SPECIFICATIONS

VALVE TYPE — SELF CONTROL VALVE PRESSURE REDUCING TYPE
SIZE — 15 mm—50 mm (1/2 inch—2 inch)
BODY MATERIAL — U-PVC
SEAL MATERIAL — EPDM etc.
CONNECTION / FLANGED — JIS, DIN, ANSI
SOCKET — JIS, DIN, ANSI
THREADED — Rc, RP, NPT
WORKING TEMPERATURE RANGE — 0-50°C
MAX.ALLOWABLE WORKING PRESSURE — 1.0MPa
ALLOWABLE PRESSURE RANGE — 0.05-0.9MPa
HIGH PURITY SERIES — WETTED PARTS LUBRICANT FREE

MANUAL



PRODUCT MODEL CODE LIST	ACTUATION	TYPE	OPERATING SYSTEM	BODY MATERIAL	SEAL MATERIAL	CONNECTION	STANDARD	SIZE	HIGH PURITY SERIES
MANUAL	V	PR	5T	U	*	*	*	***	2
	V MANUAL VALVE	PR SELF CONTROL	5T PRESSURE RELIEF TYPE	U U-PVC	E EPDM Z FKM (PTFE coating)	S SOCKET N THREADED F FLANGED	J JIS I JIS10K D DIN A ANSI	015 15mm 050 50mm	2 WETTED PARTS LUBRICANT FREE

TYPE What should be filled in the "xxx" section?

MANUAL

SELF CONTROL VALVE PRESSURE RELIEF TYPE

CONNECTION / FLANGED, SOCKET — JIS, DIN, ANSI THREADED — Rc, RP, NPT

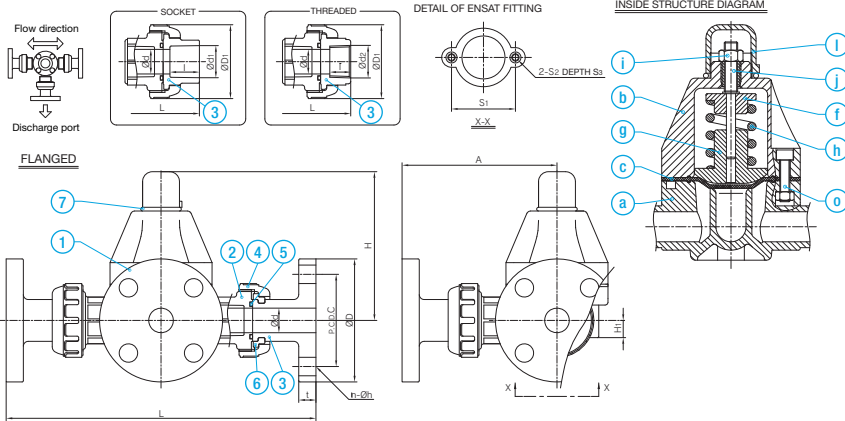

PART NO. / NAME	QTY	MATERIAL	MEMO
a BODY	1	U-PVC	
b HOUSING	1	U-PVC	
c DIAPHRAGM	1	□EPDM, □FKM-PTFE COATING	
f SPRING PLATE	1	Aluminum	
g COMPRESSOR	1	PP	
h COMPRESSION SPRING	1	Spring steel	
i LOCK NUT	1	Polyamide	
j ADJUSTING SCREW	1	—	
l CAP	1	Polystyrene	
o BOLT, WASHER, NUT	4	—	
② PJ-BODY	2	U-PVC	SELF CONTROL VALVE DEDICATED FOR TRUE UNION
③ END CONNECTOR	2	U-PVC	
④ UNION NUT	2	U-PVC	
⑤ O-RING (C)	2	EPDM (FKM*)	
⑥ STOP RING	2	PVDF	Used for flanged type.
⑦ O-RING (D)	1	EPDM	

* When the diaphragm is FKM with PTFE coating.

■ JIS, DIN (Unit: mm)		JIS															DIN																			
		FLANGED					SOCKET					THREADED					FLANGED DIN PN10/PN16			SOCKET			THREADED													
mm	d	D ₁	H	H ₁	S ₁	S ₂	S ₃	D	C	n	h	L	t	A	d ₁	ℓ	1/T	L	A	d ₂	ℓ	L	A	D	C	n	h	L	t	d ₁	ℓ	L	A	D ₂	ℓ	L
15	15	48	120	20	90	M6	9	95	70	4	15	221	12	110.5	22.11	20	1/34	186	93	Rc 1/2	15	180	90	95	65	4	14	208	12	20	16	180	Rp1/2	15	180	
20	20	60	120	20	100	M6	9	100	75	4	15	252	14	126.0	26.13	24	1/34	208	104	Rc 3/4	17	200	100	105	75	4	14	230	14	25	19	199	Rp3/4	17	240	
25	25	70	175	27	100	M6	9	125	90	4	19	302	14	151.0	32.16	27	1/34	260	130	Rc 1	20	246	123	115	85	4	14	275	14	32	22	246	Rp1	20	246	
32	31	82	159	43	115	M6	9	135	100	4	19	296	16	148.0	38.19	30	1/34	268	134	Rc 1 1/4	22	256	128	140	100	4	18	286	16	40	26	256	Rp1 1/4	22	306	
40	40	100	250	43	115	-	-	140	105	4	19	379	16	189.5	48.21	37	1/37	356	178	Rc 1 1/2	25	330	165	150	110	4	18	367	16	50	31	331	Rp1 1/2	25	330	
50	51	106	250	43	125	-	-	155	120	4	19	395	16	197.5	60.25	42	1/37	380	190	Rc 2	28	358	179	165	125	4	18	395	16	63	38	388.2	Rp2	28	358	

■ ANSI (Unit: inch)		ANSI																																
		FLANGED ANSI CLASS 150					SOCKET					THREADED																						
inch	mm	d	D ₁	H	H ₁	S ₁	S ₂	S ₃	D	C	n	h	L	t	d ₁	ℓ	1/T	L	A	d ₂	ℓ	L	A	d ₁ '	ℓ	L	A	d ₂	ℓ	L	A			
1/2	15	0.59	1.89	4.72	0.79	3.54	M6	0.35	3.50	2.38	4	0.62	8.70	0.47	0.848	0.836	0.875	7.52																
3/4	20	0.79	2.36	4.72	0.79	3.94	M6	0.35	3.88	2.75	4	0.62	9.92	0.55	1.058	1.046	1.000	8.23																
1	25	0.98	2.76	6.89	1.06	3.94	M6	0.35	4.25	3.12	4	0.62	11.89	0.55	1.325	1.310	1.125	10.24																
1 1/4	32	1.22	3.23	6.26	1.69	4.53	M6	0.35	4.62	3.5	4	0.62	11.65	0.63	1.670	1.655	1.250	10.63																
1 1/2	40	1.57	3.94	9.84	1.69	4.53	-	-	5.00	3.88	4	0.62	14.92	0.63	1.912	1.894	1.375	13.82																
2	50	2.01	4.17	9.84	1.69	4.92	-	-	6.00	4.75	4	0.75	15.55	0.63	2.387	2.369	1.500	14.57																

SELF CONTROL VALVE PRESSURE RETAINING TYPE

The pressure retaining type maintains the primary side pressure constant. The valve opens when the primary side pressure exceeds the set value and closes when the pressure falls below the set value. It works using the fluid pressure only, without using any auxiliary power. Against the fluid power pressing up the diaphragm, the valve uses the force of compression spring to press down the diaphragm so as to keep balance. For appropriate flow range, see P.237.

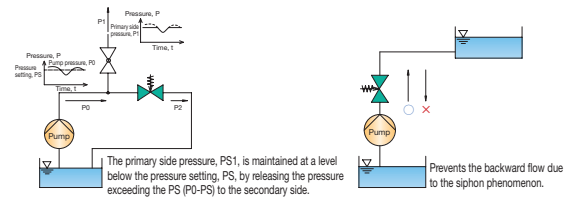

BASIC SPECIFICATIONS

VALVE TYPE — SELF CONTROL VALVE PRESSURE RETAINING TYPE
SIZE — 15 mm—50 mm (1/2 inch—2 inch)
BODY MATERIAL — U-PVC
SEAL MATERIAL — EPDM etc.
CONNECTION / FLANGED — JIS, DIN, ANSI
SOCKET — JIS, DIN, ANSI
THREADED — Rc, RP, NPT
WORKING TEMPERATURE RANGE — 0-50°C
MAX.ALLOWABLE WORKING PRESSURE — 1.0MPa
ALLOWABLE PRESSURE RANGE — 0.05-0.9MPa
HIGH PURITY SERIES — WETTED PARTS LUBRICANT FREE

MANUAL



PRODUCT MODEL CODE LIST	ACTUATION	TYPE	OPERATING SYSTEM	BODY MATERIAL	SEAL MATERIAL	CONNECTION	STANDARD	SIZE	HIGH PURITY SERIES
MANUAL	V	PR	6T	U	*	*	*	***	2
	V MANUAL VALVE	PR SELF CONTROL	6T PRESSURE RETAINING TYPE	U U-PVC	E EPDM Z FKM (PTFE coating)	S SOCKET N THREADED F FLANGED	J JIS I JIS10K D DIN A ANSI	015 15mm 050 50mm	2 WETTED PARTS LUBRICANT FREE

TYPE What should be filled in the "xxx" section?

MANUAL

SELF CONTROL VALVE PRESSURE RETAINING TYPE

CONNECTION / FLANGED, SOCKET — JIS, DIN, ANSI THREADED — Rc, RP, NPT

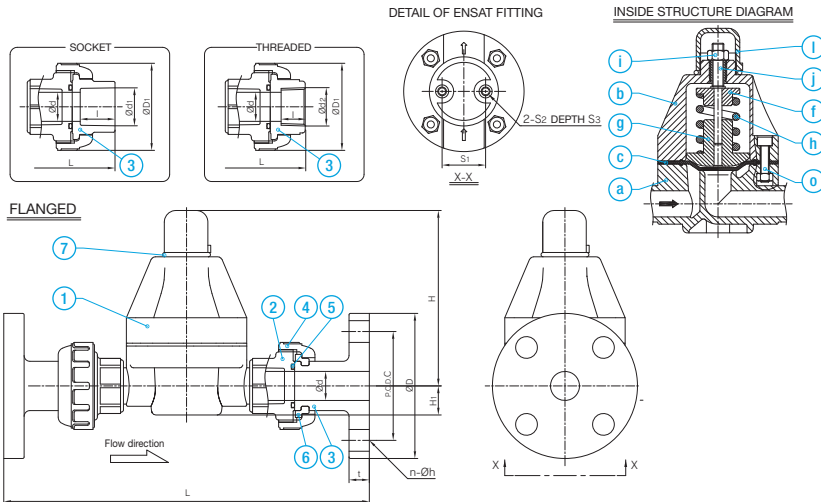

PART NO. / NAME	QTY	MATERIAL	MEMO
a BODY	1	U-PVC	
b HOUSING	1	U-PVC	
c DIAPHRAGM	1	□ EPDM, □ FKM-PTFE COATING	
f SPRING PLATE	1	ALUMINUM	
g COMPRESSOR	1	PP	
h COMPRESSION SPRING	1	Spring steel	
i LOCK NUT	1	Polyamide	
j ADJUSTING SCREW	1	—	
l CAP	1	Polystyrene	
o BOLT, WASHER, NUT	4	—	
② P-J-BODY	2	U-PVC	SELF CONTROL VALVE DEDICATED FOR TRUE UNION
③ END CONNECTOR	2	U-PVC	
④ UNION NUT	2	U-PVC	
⑤ O-RING (C)	2	EPDM(FKM*)	
⑥ STOP RING	2	PVDF	Used for flanged type.
⑦ O-RING (D)	1	EPDM	

* When the diaphragm is FKM with PTFE coating.

■ JIS, DIN (Unit: mm)

mm	d	D1	H	H1	S1	S2	S3	JIS												DIN												
								FLANGED				SOCKET				THREADED				FLANGED DIN PN10/PN16				SOCKET				THREADED				
D	C	n	h	L	t	d1	ℓ	1/T	L	d2	ℓ	L	D	C	n	h	L	t	d1	ℓ	L	D	C	n	h	L	t	d1	ℓ	L		
15	15	48	120	20	29	M6	16	95	70	4	15	221	12	22.11	20	1/34	186	Rc 1/2	15	180	95	65	4	14	208	12	20	16	180	Rp1/2	15	180
20	20	60	120	20	29	M6	16	100	76	4	15	252	14	26.13	24	1/34	208	Rc 3/4	17	200	105	75	4	14	230	14	25	19	199	Rp3/4	17	240
25	25	70	175	27	47	M6	17	125	90	4	19	302	14	32.16	27	1/34	260	Rc 1	20	246	115	85	4	14	275	14	32	22	246	Rp1	20	246
32	31	82	159	43	47	M6	17	135	100	4	19	296	16	38.19	30	1/34	268	Rc 1 1/4	22	256	140	100	4	18	286	16	40	26	256	Rp1 1/4	22	306
40	40	100	250	43	-	-	-	140	105	4	19	379	16	48.21	37	1/37	356	Rc 1 1/2	25	330	150	110	4	18	367	16	50	31	331	Rp1 1/2	25	330
50	51	106	250	43	-	-	-	155	120	4	19	395	16	60.25	42	1/37	380	Rc 2	28	358	165	125	4	18	395	16	63	38	388.2	Rp2	28	358

■ ANSI (Unit: inch)

inch	mm	d	D1	H	H1	S1	S2	S3	ANSI																																		
									FLANGED ANSI CLASS 150				SOCKET				THREADED																										
D	C	n	h	L	t	d1	d1'	ℓ	L	d2	ℓ	L	D	C	n	h	L	t	d1	d1'	ℓ	L	D	C	n	h	L	t	d1	ℓ	L												
1/2	15	0.59	1.89	4.72	0.79	1.14	M6	0.63	3.50	2.38	4	0.62	8.70	0.47	0.848	0.836	0.875	7.52	1/2-14NPT	0.59	7.09	3/4	20	0.79	2.36	4.72	0.79	1.14	M6	0.63	3.88	2.75	4	0.62	9.92	0.55	1.058	1.046	1.000	8.23	3/4-14NPT	0.67	7.87
1	25	0.98	2.76	6.89	1.06	1.85	M6	0.67	4.25	3.12	4	0.62	11.89	0.55	1.325	1.310	1.125	10.24	1-11 1/2NPT	0.79	9.69	1 1/4	32	1.22	3.23	6.26	1.69	1.85	M6	0.67	4.62	3.5	4	0.62	11.65	0.63	1.670	1.655	1.250	10.63	1 1/4-11 1/2NPT	0.87	10.08
1 1/4	40	1.57	3.94	9.84	1.69	-	-	-	5.00	3.88	4	0.62	14.92	0.63	1.912	1.894	1.375	13.82	1 1/2-11 1/2NPT	0.98	12.99	1 1/2	40	2.01	4.17	9.84	1.69	-	-	-	6.00	4.75	4	0.75	15.55	0.63	2.387	2.369	1.500	14.57	2-11 1/2NPT	1.10	14.09

GAUGE VALVE

- THE WETTED PART MADE OF CORROSION-RESISTANT PLASTIC. SEALING WITH DIAPHRAGM.
- EASY TO SET, ONLY REQUIRING THE GAUGE PIPE AND TIGHTENING THE UNION NUT.
- EQUIPPED WITH DRAIN PLUG USEFUL FOR MAINTENANCE (ALLOWING FOR COLLECTION OF SAMPLE SOLUTION).

■ The top of the gauge pipe can be fixed using a flanged elbow. (25 mm only. See the figure below.)

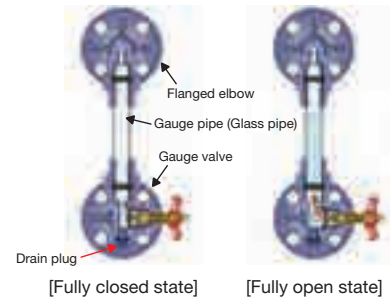

BASIC SPECIFICATIONS

VALVE TYPE ————— **GAUGE VALVE**
SIZE ————— **20 mm, 25 mm (3/4 inch, 1 inch)**
BODY MATERIAL ————— **U-PVC** **PP**
SEAL MATERIAL / O RING — **EPDM** **PTFE** etc.
CONNECTION / FLANGED — **JIS10K, DIN, ANSI**

- O.D. OF GAUGE PIPE (GLASS PIPE) MEETS $\phi 18$ FOR 20mm, $\phi 26$ FOR 25mm.
- SCREW OF DRAIN PLUG IS G1/4 FOR 20mm AND 25mm.

	FLUID TEMPERATURE	MAXIMUM WORKING PRESSURE (NORMAL TEMPERATURE) MPa(kgf/cm ²)
U-PVC	0°C ~ 40°C	0.5 {5.1}
	41°C ~ 50°C	0.4 {4.1}
	51°C ~ 80°C	—
PP	0°C ~ 40°C	0.5 {5.1}
	41°C ~ 50°C	0.4 {4.1}
	51°C ~ 80°C	0.3 {3.1}

NOTE The maximum working pressure is the value including the water hammer pressure. Be careful that the maximum working pressure is not exceeded during use.

* Concerning the allowable pressure for each temperature and material, see the technical documents at the end of this catalog.

MANUAL



MANUAL

GAUGE VALVE

CONNECTION / FLANGED — JIS, DIN, ANSI

Gauge valve JIS 10K: 20 mm (3/4 inch)

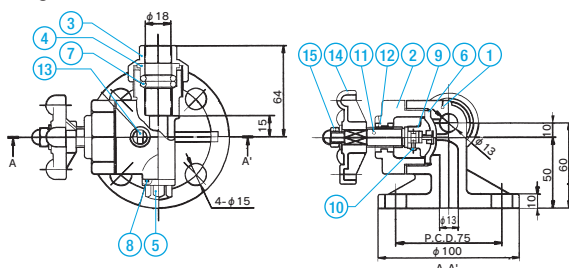

Gauge valve JIS 10K: 25 mm (1 inch)

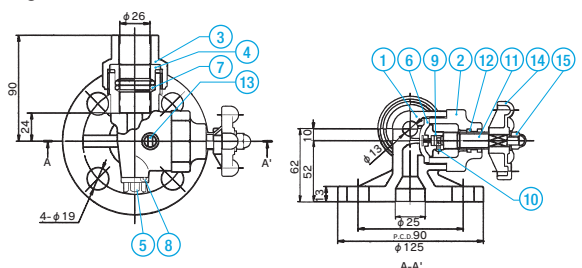

Flanged elbow JIS 10K: 25 mm (1 inch)

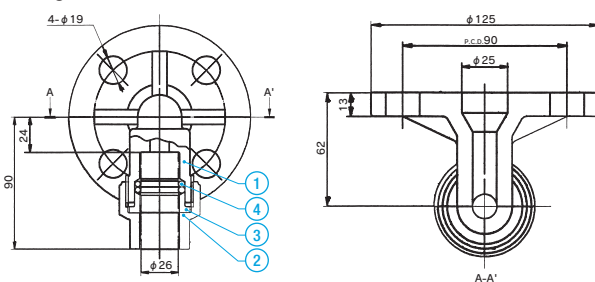

PART NO. / NAME	QTY	MATERIAL	PART NO. / NAME	QTY	MATERIAL
① BODY	1	U-PVC, PP	⑨ COMPRESSOR	1	PVDF
② BONNET	1	U-PVC, PP	⑩ COMPRESSOR PIN	2	SUS304
③ UNION NUT	1	U-PVC, PP	⑪ STEM	1	C3604
④ PACKING GLAND	1	U-PVC, PP	⑫ EMBEDDED BONNET FITTING	1	C3604
⑤ DRAIN PLUG	1	U-PVC, PP	⑬ MATERIAL INDICATION SHEET	1	Silver label
⑥ DIAPHRAGM	1	EPDM, PTFE, etc.	⑭ HANDLE	1	PP
⑦ O-RING (A)	2	EPDM, PTFE, etc.	⑮ NUT	1	SUS304
⑧ O-RING (B)	1	EPDM, PTFE, etc.			

NOTE When the diaphragm material is PTFE, the O-ring material is also PTFE.

■ JIS, DIN (Unit: mm)

										JIS10K				DIN PN10			
mm	d	L ₁	L ₂	L ₃	L ₄	L ₅	t	d ₁		D	C	n	h	D	C	n	h
20	13	60	64	50	10	15	10	18		100	75	4	15	105	75	4	14
25	25	62	90	52	10	24	13	26		125	90	4	19	115	85	4	14

■ ANSI (Unit: inch)

										ANSI Class150							
inch	mm	d	L ₁	L ₂	L ₃	L ₄	L ₅	t	d ₁	D	C	n	h	D	C	n	h
3/4	20	0.51	2.36	2.52	1.97	0.39	0.59	0.39	0.71	3.88	2.75	4	0.62				
1	25	0.98	2.44	3.54	2.05	0.39	0.94	0.51	1.02	4.25	3.12	4	0.62				

SEDIMENT STRAINER (TYPE Y)

- MATERIAL WITH HIGH RESISTANCE TO CORROSION, CHEMICALS AND WEAR.
- TRANSPARENT BODY THAT ALLOWS FOR CHECKING OF INSIDE FLOW.
- EASY SCREEN CLEANING, DISASSEMBLY/ASSEMBLY FOR REPLACEMENT AND MAINTENANCE.

[MANUAL](#)



BASIC SPECIFICATIONS

VALVE TYPE ————— **SEDIMENT STRAINER (TYPE Y)**
SIZE ————— **15 mm—100 mm (1/2 inch—4 inch)**
BODY MATERIAL ————— **U-PVC**
SEAL MATERIAL ————— **EPDM FKM etc.**
CONNECTION / FLANGED — **JIS5K, JIS10K, DIN, ANSI**
SOCKET — **JIS, DIN, ANSI**
THREADED — **Rc, Rp, NPT**

NOTES

- Avoid direct sunlight and store it indoors. Also avoid storing the valve in a place that may be exposed to high temperatures. ● Pay attention to the direction of flow when mounting the product on a pipe. (It is indicated by an arrow on the valve parts.)
- Clean the screen periodically. (Handle the screen with utmost care during cleaning.)
- Make sure during piping work that the valve is not exposed to direct sunlight.
- Note that volatile liquids, such as hydrogen peroxide solution (H₂O₂) and sodium hypochlorite (NaClO), may cause abnormal pressure increase in strainer. (When the internal pressure abnormally increases due to vaporization, the gas becomes compressive fluid. If the valve breaks in this state, it will be very dangerous, causing explosion and scattering of fragments.)
- The Y-shaped strainer, in particular, has such a structure that the corners are susceptible to the effects of repeated stress due to internal variations. Therefore, for lines where pulsation (including air hammer and water hammer) may occur, take adequate measures during piping installation. Otherwise breakage may occur. Also, perform periodic check (approx. once a year).
- Piping lines made of copper require particular attention because the effects of stress such as internal fluctuations are concentrated on the Y-shaped strainer.

	FLUID TEMPERATURE	MAXIMUM WORKING PRESSURE (NORMAL TEMPERATURE) MPa{kgf/cm ² }		CONNECTION METHOD		
		15mm—50mm	65mm—100mm	FLANGED	SOCKET	THREADED
U-PVC	0°C ~ 50°C	1.0 {10.2}	0.6 {6.1}	○	○	○

NOTE For information on chemical resistance, contact our sales office.

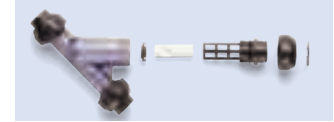

PRODUCT MODEL CODE LIST

[MANUAL](#)

ACTUATION	TYPE	MESH TYPE	BODY MATERIAL	SEAL MATERIAL	CONNECTION	STANDARD	SIZE
V	YS	**	U	*	*	*	***
⋮	⋮	⋮	⋮	⋮	⋮	⋮	⋮
V MANUAL VALVE	YS SEDIMENT STRAINER (TYPE Y)	2U 20MESH 3U 30MESH 4U 40MESH	U U-PVC	E EPDM V FKM	S SOCKET N THREADED F FLANGED	J JIS 1 JIS10K 5 JIS 5K	015 15mm ? 100 100mm

PARTS LIST [MANUAL](#)

FLANGED

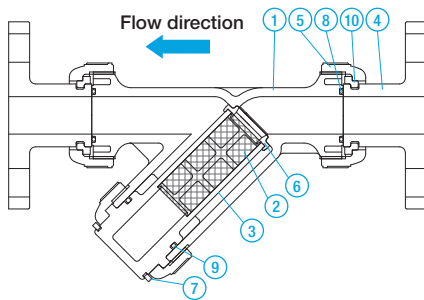

SOCKET

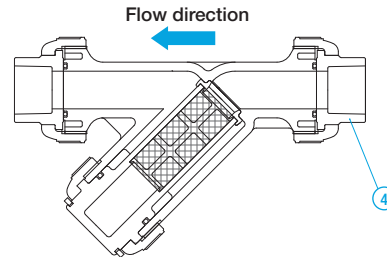

THREADED

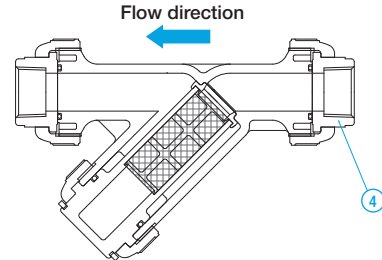

PART NO. / NAME	QTY	MATERIAL
① BODY	1	U-PVC (transparent)
② SCREEN (1)	1	U-PVC
③ SCREEN SUPPORT	1	U-PVC
④ END CONNECTOR	2	U-PVC
⑤ UNION NUT	3	U-PVC

PART NO. / NAME	QTY	MATERIAL
⑥ RETAINING RING	1	U-PVC
⑦ SPLIT RING	1	U-PVC
⑧ O-RING (A)	2	EPDM, FKM, etc.
⑨ O-RING (B)	1	EPDM, FKM, etc.
⑩ STOP RING (2)	2	PVDF

NOTES (1) 40 mesh : standard 30/20/60 mesh : custom-build *60 mesh: U-PVC (20 mesh) + PVDC (60 mesh) *For Stainless Steel mesh, consult us.
 (2) Flanged type only.

SEDIMENT STRAINER (TYPE Y)

CONNECTION / FLANGED, SOCKET—JIS, DIN, ANSI THREADED—Rc, Rp, NPT

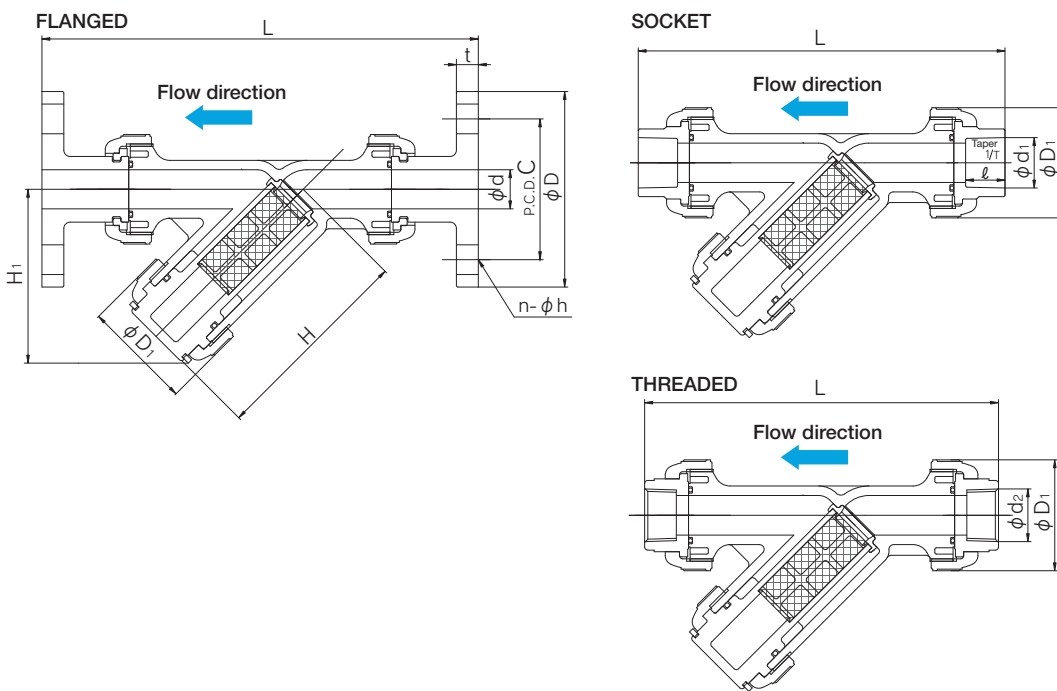

■ JIS, DIN (Unit: mm)

							JIS															
							FLANGED				SOCKET				THREADED							
mm	d	D ₁	H	H ₁	H ₂	JIS 5K				JIS 10K				L	t	d ₁	ℓ	1/T	L	d ₂	ℓ	L
						D	C	n	h	D	C	n	h									
15	15	48	97	78	134	80	60	4	12	95	70	4	15	206	12	22.11	20	1/34	172	Rc 1/2	15	165
20	20	60	120	98	168	85	65	4	12	100	75	4	15	254	14	26.13	24	1/34	210	Rc 3/4	17	202
25	25	70	133	111	189	95	75	4	12	125	90	4	19	280	14	32.16	27	1/34	238	Rc 1	20	224
32	40	100	177	149	256	115	90	4	15	135	100	4	19	336	16	38.19	30	1/34	298	Rc 1 1/4	22	287
40	40	100	177	149	256	120	95	4	15	140	105	4	19	336	16	48.21	37	1/37	313	Rc 1 1/2	25	287
50	51	106	190	160	277	130	105	4	15	155	120	4	19	361	16	60.25	42	1/37	346	Rc 2	28	324
65	78	140	271	234	399	155	130	4	15	175	140	4	19	477	18	76.60	61	1/48	487	Rc 2 1/2	32	436
80	78	152	271	234	399	180	145	4	19	185	150	8	19	477	18	89.60	64	1/49	487	Rc 3	35	436
100	100	210	361	316	537	200	165	8	19	210	175	8	19	608	18	114.70	64	1/56	653	Rc 4	45	596

DIN												
mm	FLANGED DIN PN10					SOCKET				THREADED		
	D	C	n	h	L	t	d ₁	ℓ	L	d ₁	ℓ	L
15	95	65	4	14	193	12	20	16	165	Rp 1/2	15	165
20	105	75	4	14	232	14	25	19	201	Rp 3/4	17	202
25	115	85	4	14	253	14	32	22	224	Rp 1	20	224
32	140	100	4	18	336	16	40	26	298	Rp 1 1/4	22	287
40	150	110	4	18	324	16	50	31	288	Rp 1 1/2	25	287
50	165	125	4	18	361	16	63	38	337	Rp 2	28	324
65	185	145	4	18	477	18	75	44	455	Rp 2 1/2	32	436
80	200	160	8	18	483	18	90	51	457	Rp 3	35	436
100	220	180	8	18	608	18	110	61	607	Rp 4	45	596

■ ANSI (Unit: inch)

							ANSI												
							FLANGED				SOCKET				THREADED				
inch	mm	d	D ₁	H	H ₁	H ₂	ANSI CLASS150				ASTM SCH80				d ₂	ℓ	L		
							C	D	n	h	L	t	d ₁	d ₁ '				ℓ	L
1/2	15	0.59	1.89	3.82	3.07	5.28	3.50	2.38	4	0.62	8.11	0.47	0.848	0.836	0.875	6.93	1/2-14 NPT	0.59	6.50
3/4	20	0.79	2.36	4.72	3.86	6.61	3.88	2.75	4	0.62	10.00	0.55	1.058	1.046	1.000	8.31	3/4-14 NPT	0.67	7.95
1	25	0.98	2.76	5.24	4.37	7.44	4.25	3.12	4	0.62	11.02	0.55	1.325	1.310	1.125	9.37	1-11 1/2 NPT	0.79	8.82
1 1/4	32	1.57	3.94	6.97	5.87	10.08	4.61	3.50	4	0.62	13.23	0.63	1.670	1.655	1.250	11.73	1 1/4-11 1/2 NPT	0.87	11.30
1 1/2	40	1.57	3.94	6.97	5.87	10.08	5.00	3.88	4	0.62	13.23	0.63	1.912	1.894	1.375	12.13	1 1/2-11 1/2 NPT	0.98	11.30
2	50	2.01	4.17	7.48	6.30	10.91	6.00	4.75	4	0.75	14.21	0.63	2.387	2.369	1.500	13.31	2-11 1/2 NPT	1.10	12.76
2 1/2	65	3.07	5.51	10.67	9.21	15.71	7.01	5.49	4	0.75	18.78	0.71	2.889	2.868	1.752	17.95	2 1/2-8 NPT	1.26	17.17
3	80	3.07	5.98	10.67	9.21	15.71	7.50	6.00	4	0.75	18.78	0.71	3.516	3.492	1.875	17.83	3-8 NPT	1.38	17.17
4	100	3.94	8.27	14.21	12.44	21.14	9.00	7.50	8	0.75	23.94	0.71	4.518	4.491	2.000	23.07	4-8 NPT	1.77	23.46